

FIGHTER X

FN62 F HD R PRO | 270 PS | 6X4
FN62 F HD PRO | 270 PS | 6X4



FEBRUARI 25



www.ktbfuso.co.id



Performa



*Tersedia 2 tipe ban:
Radial & Bias

270PS Common Rail

Mesin 6M60 yang dilengkapi dengan **Variable Geometry Turbocharger (VGT)** mampu menghasilkan torsi dan tenaga maksimal di putaran mesin yang rendah.

Dengan **Exhaust Gas Recirculation (EGR)** dan **Positive Crankcase Ventilation (PCV)** yang didukung oleh **Diesel Oxidation Catalyst (DOC) Muffler** menghasilkan emisi gas buang ramah lingkungan.



Chassis Kuat

Chassis tebal tanpa sambungan dengan posisi kelingan (rivet) di sisi samping, sehingga meningkatkan daya tahan chassis dan mempermudah dalam pemasangan **rear body**.

Fitur Khusus



Higher Bumper Clearance

Posisi bumper lebih tinggi, cocok untuk di medan off-road



Radiator Guard

Melindungi radiator dari lumpur dan bebatuan.

Keselamatan & Kenyamanan



Full Air Brake System + ABS

Dengan pengereman **Full Air Brake System + ABS**, dapat menambah keamanan saat di perjalanan.

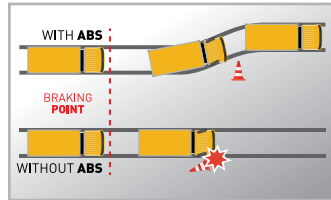

Telematic System



Dimensi Kendaraan

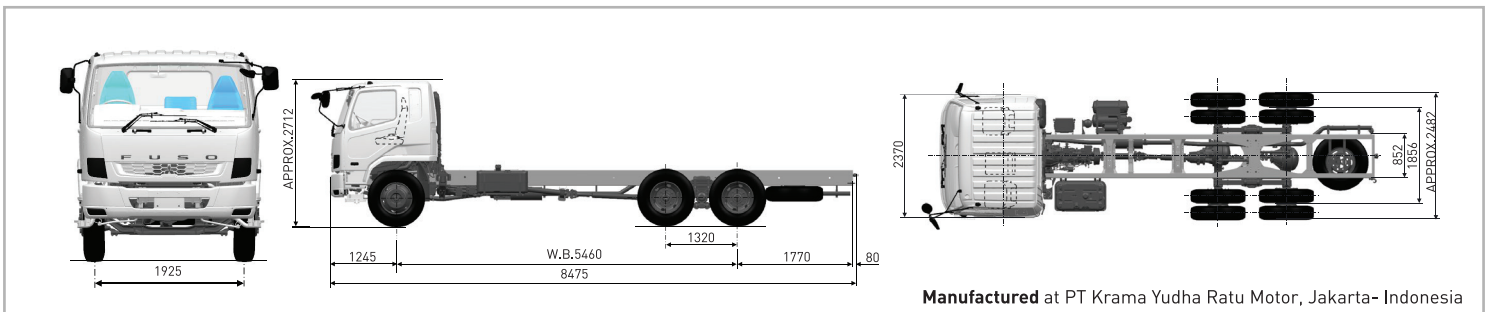

Manufactured at PT Krama Yudha Ratu Motor, Jakarta- Indonesia

MODEL 6x4 : FN62F HD PRO & FN62F HD R PRO

DIMENSI		KEMAMPUAN		REM	
Jarak Sumbu Roda	5.460 mm	Kecepatan Maksimum	77 km/jam (FN62F HD R)	Rem kaki (Service brake)	Full air, dual circuit, wedge type
Panjang Keseluruhan	8.475 mm		76 km/jam (FN62F HD)	Rem tangan (Parking brake)	Spring loaded type on rear wheels by hand control valve
Lebar Keseluruhan	2.482 mm	Daya tjanak dengan Max G.V.W	58 %	Rem pembantu	Sistem pengereman gas buang (Exhaust brake)
Tinggi Keseluruhan	2.712 mm	Radius putar minimum	9.0 m	SUSPENSI	
Jarak roda depan kiri-kanan	1.925 mm	BAN & RODA		Depan	Laminated leaf springs dengan shock absorber
Jarak roda belakang kiri-kanan	1.856 mm	FN62F HD		Belakang	Inverted and laminated leaf springs with trunion base and radius rods
KABIN PENGEMUDI		Ban depan	Tunggal, 11.00-20-16PR (Rib-Lug)		
Tipe	All steel, tilt cab (Kabin Jungkit)	Ban belakang	Ganda, 11.00-20-16PR (Rib-lug)	KEMUDI	
				Tipe	Ball nut type with integral type hydraulic power booster, telescopic & tilt steering column with steering lock

KAPASITAS BAHAN BAKAR			TRANSMISI		MESIN			
Tangki	200 liter		Model	EATON ES-11109		Model	6M60 - DAT6	
BERAT	FN62F HD	FN62F HD R	Tipe	9 gigi maju dan 1 gigi mundur		Tipe	4 Stroke-cycle water cooled direct injection turbocharged diesel engine, Common Rail, EURO4	
Berat chassis termasuk kabin	7.270 kg	7.568 kg	Perbandingan gigi	12.640 - 8.810 - 6.550 - 4.770 - 3.550 - 2.480			Diameter X Langkah	118x115 mm
Depan	3.000	3.110		- 1.850 - 1.340 - 1.000 Mundur 13.21			Isi Silinder	7.545 cc
Belakang	4.270	4.458	Perbandingan gigi akhir	7.400			Daya Maksimum	270/2.400 PS/rpm
Max G.V.W	26.000 kg		Tipe Kopling	Hydraulic control, coil spring type, single dry plate with air pressure assistance			Torsi Maksimum	880/1.200 - 2.000 Nm/rpm
Depan	6.000 kg		SISTEM KELISTRIKAN					
Belakang	20.000 kg		Tegangan	24 V				

CATATAN : Untuk peningkatan & penyesuaian dengan perkembangan teknologi, spesifikasi ini sewaktu-waktu dapat berubah tanpa pemberitahuan terlebih dahulu.

*Syarat dan ketentuan berlaku.